

Portable Edgebander

- Easy to use, extremely flexible
- Only 7 mins to warm up
- Works with ABS, PVC, Melamine & Veneer.
- Hot-melt edgebander for the price of a hot-air machine.
- Ideal for on-site repairs or specialty and custom banding.

optional accessories included during Promo

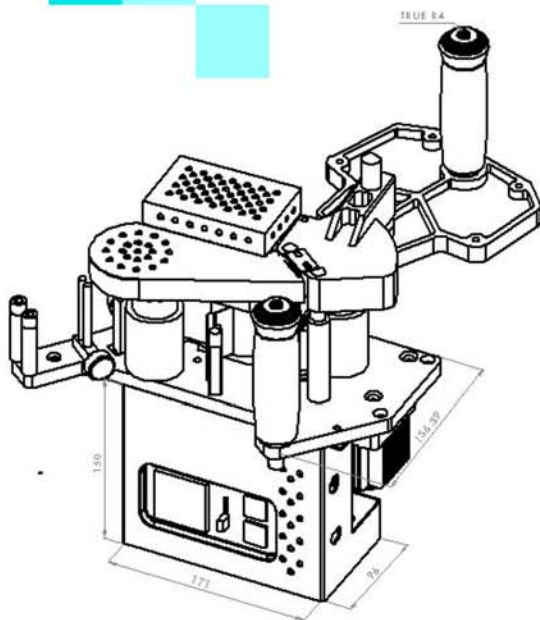

MODEL

AEB1-HHB

TYPE OF EDGEBOARDING	ABS, PVC, Melamine & Veneer.
THICKNESS OF EDGEBOARDING	0.3mm~3mm (1/64"~1/8")
EDGEBOARDING WIDTH	10mm~60mm (3/8"~2-3/8")
EDGEBOARDING LENGTH	200mm~INFINITE (8"~∞)
MINIMUM INSIDE RADIUS	20mm (3/4") DEPENDING ON MATERIAL
VOLTAGE	220V/110V 1 PH
HEATER POWER	625W
FEED POWER	20W
TOTAL POWER	645W
GLUE POT MAXIMUM TEMPERATURE	200°C (400°F)
GLUE POT CAPACITY	320ml (0.3QT)
FEED SPEED	VARIABLE 2-6m/min (6~20ft/min)
MACHINE DIMENSION (PACKED DIMENSIONS WITH CARRYING CASE)	33x34x40cm / 46x43x51cm (13x13x15.5" / 18x17x20")
MACHINE WEIGHT (PACKED WEIGHT)	9.5kg / 40kg (21LBS / 88LBS)

www.specialtytools.com
1.800.669.5519



ACTIVA

PORTABLE HOT MELT EDGE BANDER

Specialtytools.com

1 800 669 5519



MODEL AEB1-HHB

**FOR CONTOURS
AND STRAIGHT
EDGBANDING**

