

GLASS & STONE

STORAGE SYSTEMS

GROVES INCORPORATED

Distributed by Specialtytools.com
1 800 669 5519

GROVES INCORPORATED

Jumbo Slab Rack - JSR-2.5 Up to 9,000 lb. Capacity

- Designed for jumbo size stone bundles. Holds up to 9,000 lbs. between two posts. Maximum weight is 4,500 lbs. per post.
- Outside rails are designed with slots to hold 2 x 4's.
- 2 x 4's protect the slab edges and the finish on the rails.
- Galvanized rails 11" wide x 5.5" high x 60" long butt together for desired length.
- Outside rails have 2.5" square holes spaced 5" apart on the top. A steel plate with identical holes is welded and boxed inside the rails, 1" up from the bottom.
- 2.5" square tube posts with a galvanized finish.
- Rails shipped with 11" connector tube for butting rails together in a straight line.



- **SAFETY WARNING: Bottom rails must be bolted to the floor for safety.**
- **SAFETY WARNING: Maximum weight allowed per bundle is 9,000 lbs. (4,500 lbs. per post).**

Part No.	Description	Weight-lbs.
BR2.5	Distributed by Specialtytools.com 1 800 669 5519	
SP-72	heavy duty 2.5" x 2.5" x 0.1875" wall thickness, 72" post height	37

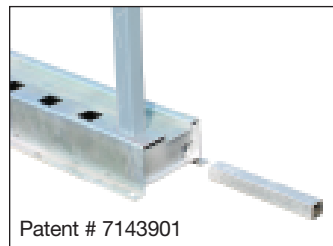
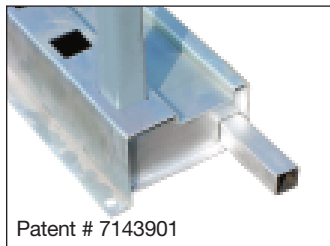

Note: When assembled the overall usable height of the post is 5.5" less than listed.
Example: a 72" post will be 66.5" above the top of the outside rail.

SUGGESTED PACKAGES FOR HEAVY DUTY BUNDLE RACK

Part No.	Overall Length	Number of Openings	Parts included in package	Weight-lbs.
3-H72	5'	3	2 BR2.5, 8 SP-72	410
6-H72	10'	6	4 BR2.5, 14 SP-72	746
12-H72	20'	12	8 BR2.5, 28 SP-72	1,492
18-H72	30'	18	12 BR2.5, 42 SP-72	2,238
30-H72	50'	30	20 BR2.5, 70 SP-72	3,730
60-H72	100'	60	40 BR2.5, 140 SP-72	7,460

Distributed by Specialtytools.com
1 800 669 5519

GLASS & STONE STORAGE SYSTEMS

Bundle Rack - BR-5 Up to 6,000 lb. Capacity

- Store bundles or slabs up to 6,000 lbs. between posts. (3,000 lb. capacity per post.)
 - Outside rails are designed with slots to hold 2 x 4's.
 - 2 x 4's protect the slab edges and the finish on the rails.
 - 11" wide x 5.5" high x 60" long. Rails butt together for desired length.
 - Outside rails have 2" square holes spaced 4" apart on the top. A steel plate with identical holes is welded and boxed inside the rails, 1" up from the bottom.
 - Hot dip galvanized finish on rails.
 - 2" square tube posts are coated with a galvanized finish.
 - Optional 2" square rubber post caps are used to prevent scratches.
 - Rails shipped with 11" connector tube for butting rails together in a straight line.
- * **SAFETY WARNING: Use .5" holes located on bottom flange for securing rails to the floor.**



MAXIMUM WEIGHT ALLOWED PER BUNDLE: 6,000 LBS. (3,000 LBS. PER POST) USE HDBR-2.5 HEAVY DUTY BUNDLE RACK FOR JUMBO SIZES WITH WEIGHTS UP TO 9,000 LBS. (4,500 LBS. PER POST)

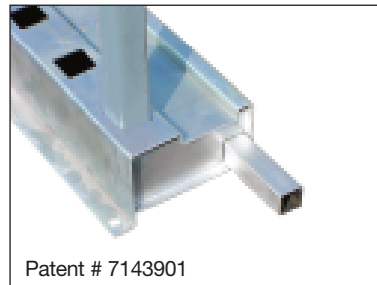

Note: When assembled the overall usable height of the post is 5.5" less than listed.

Example: a 60" post will be 54.5" above the top of the outside rail.

Part No.	Description	Weight-lbs.
BR-5	Outside rail with wood slot	55
SP-40	40" posts for storing smaller fabricated parts and cut-offs	10
SP-60	60" posts for storing standard sized slabs	15
SP-80	80" posts for storing taller oversized slabs	19
PC-2	Scratch resistant rubber post caps	1

SUGGESTED PACKAGES FOR BUNDLES OR SLABS USING 60" POSTS

Part No.	Overall Length	Number of Openings	Parts included in package	Weight-lbs.
4-W60	5'	4	2 BR-5, 10 SP-60	260
9-W60	10'	9	4 BR-5, 20 SP-60	520
19-W60	20'	19	8 BR-5, 40 SP-60	1,040
49-W60	50'	49	20 BR-5, 100 SP-60	2,600

Distributed by Specialtytools.com
1 800 669 5519

GROVES INCORPORATED

Back Splash Brackets

- Store a large quantity of back splashes in a small area.
- BSB-23 brackets mount on 2" square posts and stack one on top of each other.
- Store back splashes on end to prevent breakage.
- Brackets are used in conjunction with our Bundle Rack storage system. They can be mounted on existing bundle racks or as packages listed below.

Part No.	Width	Height	Length	Description	Weight-lbs.
BSB-23	NA	12"	23"	Back Splash Brackets	15
BR-5	11"	5.5"	60"	Bundle Rail	55
SP-60	2"	2"	60"	60" Post	15

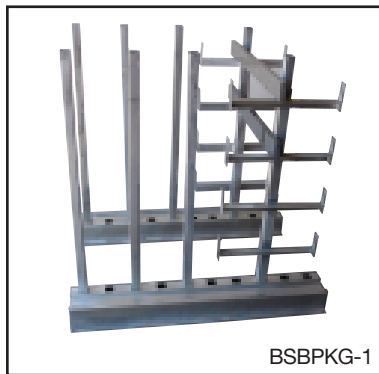

BSBPKG-1

BSBPKG-1

One row with four levels of back splash storage. Three posts on each rail provide two 12" wide sections between the posts for stone storage.

Parts included in the package:

2 BR-5, 8 BSB-23, 8 SP-60.

BSBPKG-2

Two rows with four levels each provide eight levels of back splash storage.

Parts included in the package:

2 BR-5, 16 BSB-23, 4 SP-60.

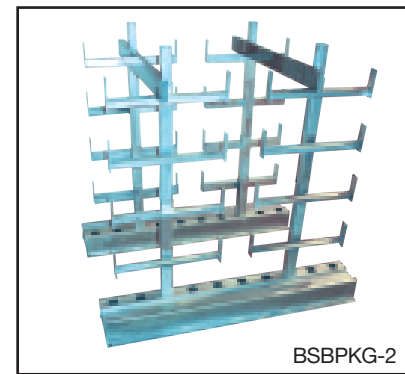

BSBPKG-2

Back Splash Packages

Part No.	Parts included in package	Weight
BSBPKG-1	2 BR-5, 8 BSB-23, 8 SP-60	350
BSBPKG-2	2 BR-5, 16 BSB-23, 4 SP-60	410

Display Rack

- 3,000 lb. capacity, 350 lb. maximum per ledge.
- Displays eight full size tops up to 3 cm thick.
- Black enamel finish.
- Use .5" holes located on the bottom for securing to the floor.

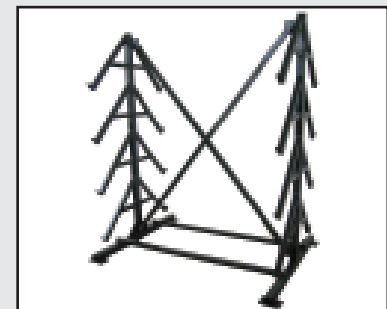

Part No.	Length	Width	Height	Ledge	Weight-lbs.
DR-8	72"	50"	78"	26.5"	230

Distributed by Specialtytools.com
1 800 669 5519

GLASS & STONE STORAGE SYSTEMS

Stacking Racks



Designed to be Stacked Three High with a Stationary Bottom. Wheels can only be used when not stacked. Maximum capacity is 3,000 lbs. total.

- One rack can hold 3,000 lbs. If stacked three high, each rack can only hold 1,000 lbs.
- Storage of remnants, cut offs, strips and cut to size pieces.
- Job site cart for safe transport and handling of countertops, vanity tops, saddles, sills and stair treads.
- Will roll through a 30" wide door opening.
- Removable front legs for easy hand loading and unloading.
- Hold down bars to secure the material to the box and prevent damage in transport.
- Cable hooks for crane handling.
- Loops for fork lift safety.
- 5" diameter Casters, two rigid and two swivel.
- 48.5" overall height w/casters, 24" load height.



Part No.	Width	Depth	Height	Ledge	Weight-lbs.
SR-1	55"	27"	41"	18"	200
SRCK-5 Caster Kit					35

Slab Top A-Frame

- Designed to hold prefabricated slab tops.
- Ideal for holding manufactured kitchens.
- Rubber is mounted on the base and the uprights to help protect product.
- Can be used with pallet racking to maximize storage.

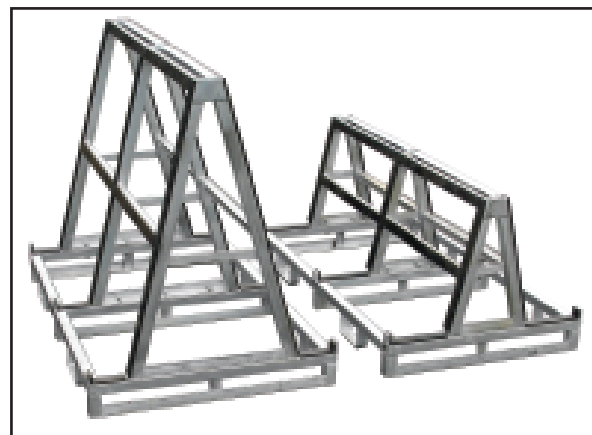

Part No.	Length	Width	Height	Ledge	Weight-lbs.
STA-24	72"	39"	24"	10.5"	208
STA-48	72"	43"	48"	5.9"	270

GROVES INCORPORATED

Multi Purpose Glass Storage System

- Holds wood or glass pack cases, up to 4,000 lbs., between posts.
- Store loose lites, insulated glass, tempered glass, plastic sheets, shower doors and more.
- Rails 11" wide x 5.5" high x 60" long, butt together for desired length.
- Outside rails have 2" square holes spaced 4" apart on the top. A steel plate with identical 2" holes is welded and boxed inside the rails, 1" up from the bottom.
- 2" square galvanized posts.
- Optional Easy Slide, a low friction material, is mounted to the rails and posts for ease of sliding products in and out.
- The center rail with Easy Slide must be used to support the glass when sliding individual pieces in and out of the racks.



SAFETY WARNING: Use .5" holes located on bottom flange for securing rails to the floor.

Distributed by Specialtytools.com
1 800 669 5519

GLASS & STONE STORAGE SYSTEMS

MULTI PURPOSE GLASS STORAGE SYSTEM

Part No.	Description	Weight-lbs.
BR-5	Outside Rail	55
BR-5ES	Outside Rail w/easy slide	60
CR-5ES	Center Rail w/easy slide	30
SP-60	Post 60" long	15
SP-80	Post 80" long	19
SP-102	Post 102" long	26
SP-60ES	Post 60" long w/easy slide	16
SP-80ES	Post 80" long w/easy slide	20
SP-102ES	Post 102" long w/easy slide	28

Note: When assembled, the overall usable height of the post is 5.5" less than listed. Example: A 60" post will be 54.5" above the top of the outside rail.

SUGGESTED WOOD CASE PACKAGES

Part No.	Overall Length	Number of Openings	Parts included in package	Weight-lbs.
4pak	5'	4	2 MP-5, 6 MP-60, 4 MP-80	250
9pak	10'	9	4 MP-5, 10 MP-60, 10 MP-80	508
19pak	20'	19	8 MP-5, 16 MP-60, 16 MP-80, 8 MP-102	1104
49pak	50'	49	20 MP-5, 24 MP-60, 36 MP-80, 40 MP-102	3004

SUGGESTED EASY SLIDE PACKAGES FOR GLASS PACKS, LOOSE LITES AND WOOD CASES

Part No.	Overall Length	Number of Openings	Parts included in package	Weight-lbs.
4pakES	5'	4	2 MP-5ES, 1 CR-5ES, 6 MP-60ES, 4 MP-80ES	324
9pakES	10'	9	4 MP-5ES, 2 CR-5ES, 10 MP-60ES, 10 MP-80ES	596
19pakES	20'	19	8 MP-5ES, 4 CR-5ES, 16 MP-60ES, 16 MP-80ES, 8 MP-102ES	1272
49pakES	50'	49	20 MP-5ES, 10 CR-5ES, 24 MP-60ES, 36 MP-80ES, 40 MP-102ES	3404

Distributed by Specialtytools.com
1 800 669 5519

GROVES INCORPORATED

Heavy Duty Transport Racks - 4,000 lb. Capacity

- Designed for transporting and storing product in your shop or on the job.
- Fork lift hoops mounted on sides.
- Bottom pads and uprights have full length rubber strips.
- Quick release mounting pins change the Transport Rack from mobile to stationary in less than a minute.
- Hot dip galvanized finish.

Part No.	Length	Width	Load Height	Overall Height	Height w/ Casters	Weight-lbs.
TR4482 4000 pound capacity	82"	44"	48"	58"	69"	540
TR4496 4000 pound capacity	96"	44"	60"	70"	81"	740
CK-4 8" diameter Caster Kit for TR4482 & TR4496						40

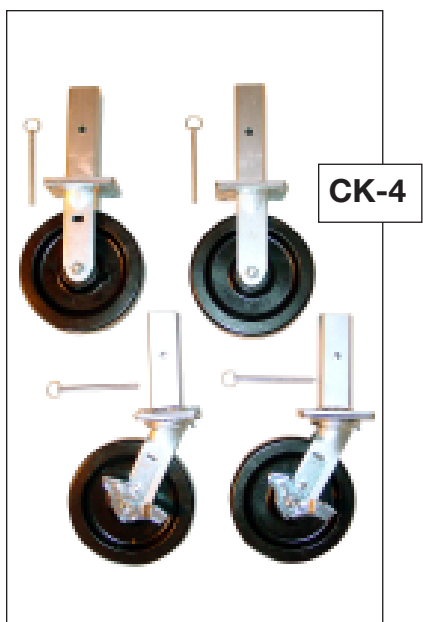
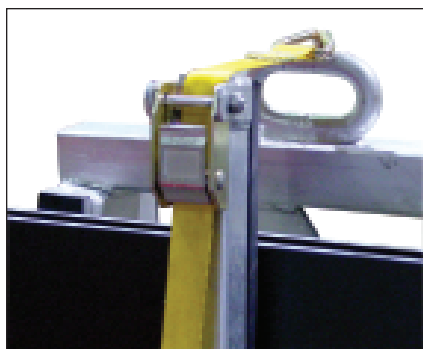

CK-4



TR4482

TR4496



Distributed by Specialtytools.com
1 800 669 5519

GLASS & STONE STORAGE SYSTEMS

Heavy Duty Transport Racks

- 10,000 lb. capacity designed to hold all sizes of slabs.
- Optional caster package consists of 8" diameter roller bearing wheels rated at 2,000 lbs. each. Two swivel casters with brakes on one end and two rigid on the other.
- Lift with overhead crane using four base mounted lifting rings. Four hold down ratchet straps secure load.

Part No.	Length	Width	Load Height	Overall Height	Height w/ Casters	Weight-lbs.
TR-10	96"	48"	78"	88"	99"	1,095
10,000 pound capacity (without casters*)						
CK-8000	8" diameter Caster Kit for TR-10 (2,000 lb. capacity per caster)					80
* SAFETY WARNING: The capacity of the TR-10 is reduced to 8,000 lbs. with the use of the CK-8000 caster kit.						

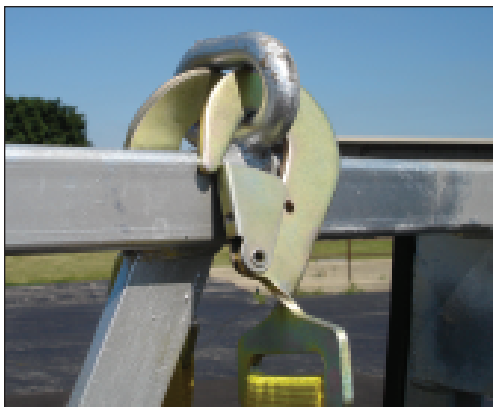

Posts shown in safe unloading position.



Posts store here during transport.

• Strongest fabrication rack available - 10,000 lb. Capacity

- Four adjustable safety posts provide for safe removal of unstrapped loads that may shift unexpectedly.
- Safety posts are stored at the end of the A-Frame during transport.

Distributed by Specialtytools.com
1 800 669 5519

GROVES INCORPORATED

Designed for Delivery and Cube Vans

- Two sizes available, designed to transport all sizes of fabricated product.
- Rubber strips mounted on bottom and back supports.
- Uprights mount in slotted holes for full depth adjustments.
- Hold downs have full length rubber strips and quick release straps.
- Hot dip galvanized finish.
- Mounting pads front and back for bolting to truck floor.
- Heavy duty construction fabricated with 1.5" square steel tubing. Stronger than competitive models.
- Ships knocked down, top A-Frame assembly is one piece bolted to the frame to save on freight costs.

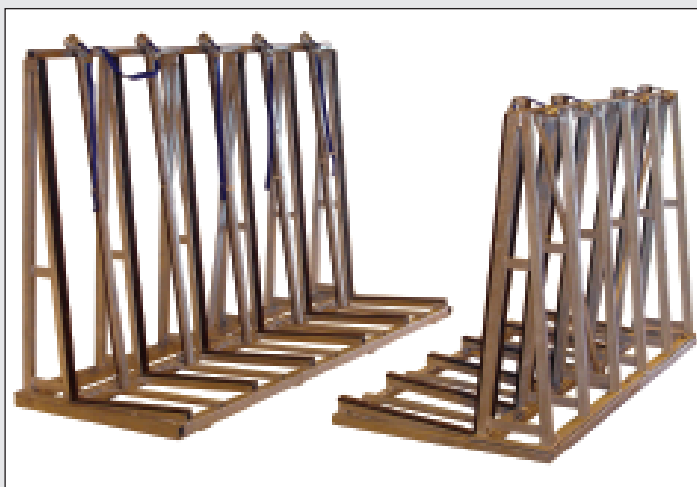

Part No.	Length	Width	Load Height	Overall Height	Hold Downs	Weight-lbs.
TRSS2482	82"	24"	48"	50.5"	4	340
TRSS2496	96"	24"	60"	63"	5	375

Econo A-Frame

- Heavy duty, 146 lb. Steel A-Frame Rack.
- 24,000 lbs. capacity/12,000 lbs. per side.
- Ships knocked down for lower freight cost.
- Hot dip galvanized finish.
- Bottom U-channel is 4" wide with 1" side ledges and is designed to hold wood 2 x 4's to support the load. Customer furnishes the wood.

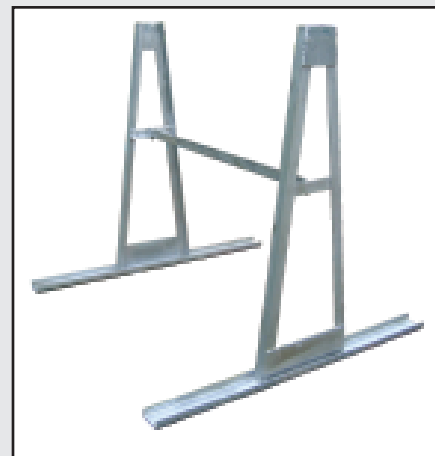

Part No.	Length	Width	Height	Spread at Top	Weight-lbs.
Econo A-Frame	60"	60"	58"	6"	146

Distributed by Specialtytools.com
1 800 669 5519

GLASS & STONE STORAGE SYSTEMS

Truck Mounted A-Frame

- 24,000 lb. total capacity. Holds up to 12,000 lbs. per side.
- Six mounting plates used for bolting to truck or trailer.
- Bottom U-channel is 4" wide with 2" side ledges and is designed to hold wood 4 x 4's to support the load. Customer furnishes the wood.
- Rubber-lined uprights.
- Removable X and cross braces bolt together for ease of transporting, and reduces shipping costs.
- Galvanized finish for long-lasting durability.



Part No.	Length	Width	Height	Ledge	Weight-lbs.
TMA-6078	60"	48"	78"	13"	530

Glass and Stone Dollies

- Maneuvers easily indoors and out.
- 3" wide neoprene rubber is easy to clean, prevents slippage and lasts for years.
- Pneumatic tires reduce breakage caused by vibration.
- 12" width measured from outside of wheels adds stability.
- 1,000 lb. capacity using 10" tires and 4" casters.
- 500 lb. capacity using 8" tires and 3" casters.

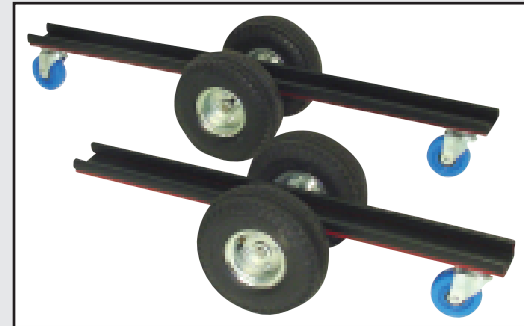

Model No.	Length	Trim Size	Caster Size	Channel Height	Weight-lbs
SD-36	36"	10"	4"	6.5"	25
SD-48	48"	10"	4"	6.5"	30
SD-72	72"	10"	4"	6.5"	40
GD-48	48"	8"	3"	5.5"	28
GD-72	72"	8"	3"	5.5"	34

Distributed by Specialtytools.com
1 800 669 5519

GROVES INCORPORATED

Heavy Duty Shop Carts

- Rugged 4,000 lb. capacity.
- Rubber is mounted on bottom and upright supports.
- Ratchet straps are included to secure load.
- 8" diameter casters rated 1,000 lbs. each. Two rigid and two swivel with brake.
- Pull handle mounted on one end for maneuverability.
- Galvanized finish for long lasting durability.



Part No.	Length	Width	Load Height	Overall Height	Weight-lbs.
HDSC48	54"	38"	48"	62"	215
HDSC8448	84"	40"	48"	63"	360
HDSC8472	84"	40"	72"	87"	460

Distributed by Specialtytools.com
1 800 669 5519

GLASS & STONE STORAGE SYSTEMS

Single Sided Shop Cart

- Holds fabricated parts.
- Removable top A-Frame for economical shipping.
- 7" ledge depth.
- 10" diameter pneumatic tires.
- 5" diameter swivel locking casters.
- 2,000 lb. capacity.



Part No.	Length	Width	Overall Height	Load Height	Weight-lbs.
SSSC-4036	40"	24"	45"	36"	130

Buggy Buddy

- Neoprene rubber on the uprights and 6" wide removable wood floor.
- Pneumatic tires are ideal for use on smooth or rough surfaces, indoors or out.
- Heavy duty 5" swivel casters with locking brakes.
- Tires and casters are positioned outside of the welded steel frame for stability.
- 24" wide for use in narrow areas and on the job site.
- Rugged 2,000 lb. capacity, total weight 135 lbs.



Part No.	Length	Width	Overall Height	Load Height	Weight-lbs.
BB-40	40"	24"	45"	35"	135

Distributed by Specialtytools.com
1 800 669 5519

GROVES INCORPORATED

Flip Cart

- Allows suction cups to be moved from one side of the stone to the other.
- Ideal for removing stone from a bridge saw then flipping stone to the other side for placing on fabrication table.
- Removable 60" posts allow adjustable spacing between posts, from 3.5" to 10 inches apart.
- Holds up to 6 pieces of 3 cm stone.
- Rubber is mounted on bottom to protect material.
- 8" diameter swivel casters with brake rated at 1,000 lbs. each.

Part No.	Length	Width	Overall Height	Post	Weight-lbs
FC4842	48"	42"	66"	60"	245



Adjustable Work Table

- Two methods of leveling adjustment.
- Adjustable working height from 40" to 44".
- Ships knocked down for freight savings.
- Rubber is mounted on top to protect material.
- Large 36" opening provides easy access for grinding and polishing hard to reach sink cutouts.

Part No.	Length	Width	Adjustable Height	Weight-lbs.
AWT2896	96"	28"	40" - 44"	296

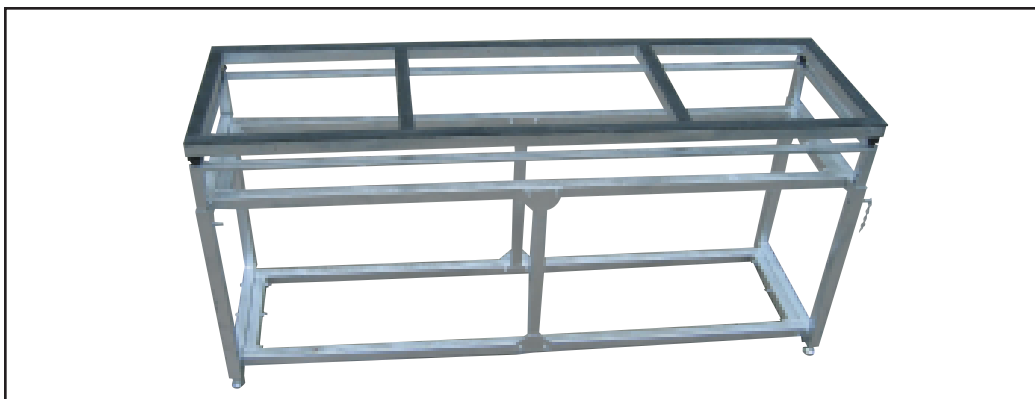

Distributed by Specialtytools.com
1 800 669 5519

GLASS & STONE STORAGE SYSTEMS

■ Tilt Table Cart

- Dual purpose fabrication and transport cart.
- Adjustable length material stops.
- Adjustable height 36" to 42"
- Four swivel 5" diameter casters, 1,000 lb. capacity each.
- Four heavy duty foot operated locks prevent movement while fabricating.
- Hot dip galvanized finish.
- Ships knocked down for freight savings.

Part No.	Trim Size	Width	Adj. Height	Weight-lbs
TT3272	72"	32"	36" - 42"	250

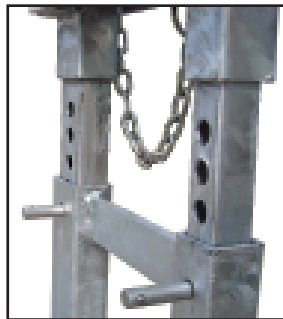
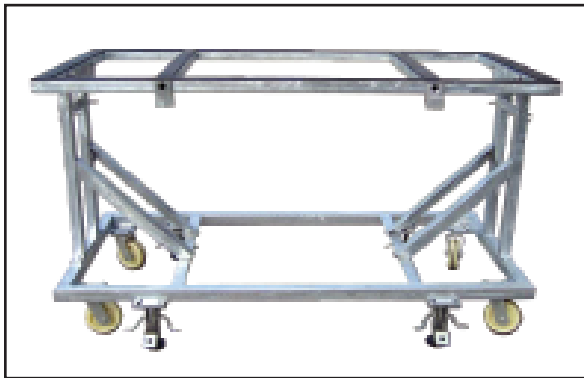

■ Cut-Out Stand

- Designed to support sink cutouts during fabrication.
- 12" x 12" base to support material
- Ships UPS for freight savings

Part No.	Adjustable Height	Weight-lbs.
Cut-Out Stand	23.5" to 40"	8

Distributed by Specialtytools.com
1 800 669 5519

GROVES INCORPORATED

▀ Fab Stand

- Fabrication stand can be used in the shop or on the job.
- Adjustable to any height from 36" to 42".
- Stackable for transporting or storage.
- Rubber mounted on top prevents sliding and scratches.
- Set up your entire job to ensure correct fit to templates and continuity of polish.



FS-24 Fab Stand

Part No.	Weight-lbs
FS-24	24



2 Fab Tables joined together
*see description below

▀ Fabrication Table

- Lay out complete kitchens by attaching the tables together lengthwise or by attaching them on a 90 degree angle.
- Two built-in end clamps hold the tables together.
- Rubber is mounted on top and the sides where the carts clamp together.
- Four heavy duty 5" diameter swivel casters rated at 1,000 lbs. each.
- Four foot operated locks hold the table in place.
- Galvanized finish for long lasting durability.



Part No.	Length	Width	Height	Weight-lbs.
DT2560	60"	25"	42"	176

Distributed by Specialtytools.com
1 800 669 5519

GLASS & STONE STORAGE SYSTEMS

Dumpster

- Convenient lever action, assures safe dumping.
- 4,000 lb. capacity.
- Continuous length fork lift tubes add stability when unloading.
- Heavy duty construction. Unit is made with heavy duty steel plate.
- Dumpster has 1 cubic yard of capacity.
- Optional 8" x 2" casters, two swivel with brake and two rigid, improve mobility.

Part No.	Length	Width	Height w/ Casters	Weight-lbs.
DP-1	63"	41"	46"	750
CK-4	(2) 8" x 2" Swivel Brake and (2) 8" x 2" Rigid Casters			40



Forklift Tubes

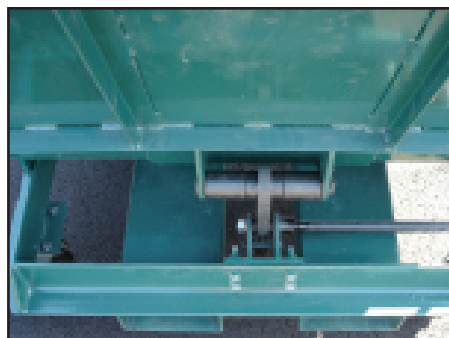

Heavy Duty Safety Lock



Safety Feature!
External Release Lever

Distributed by Specialtytools.com
1 800 669 5519

GROVES INCORPORATED

Slings and Shoes for Glass

- Workloads are rated 9,600 lbs. per sling in a vertical lift.
 - The inside of slings and horizontal straps are covered with reinforced PVC coated material to help prevent cutting.
 - Made with 3" wide polyester webbing which minimizes elongation to 3% or less.
 - Velcro straps prevent slings from shifting on beam when not under load.
 - Shoes are lined with neoprene rubber and have end ledges that prevent sling from contacting exposed glass.
 - Shoes are held in place with a quick release pin for easy mounting and removal. The quick release pin prevents the shoe from falling off.
- * **SAFETY WARNING:** Check slings for wear and damage before each use.

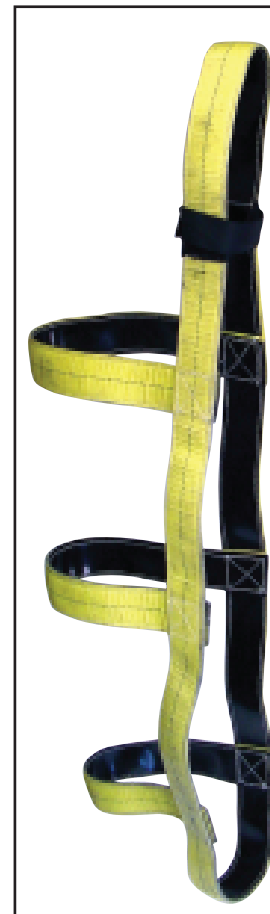

Part No.	Description
78S	78" long for glass 36" up to 54" high
108M	108" long for glass 60" up to 84" high
124L	124" long for glass 72" up to 100" high
160J	160" long for Jumbo case 130" up to 204"



Part No.	Description
SH-(SIZE)	Shoe widths for glass packs 4.75", 6.75", 8.5", 10.25", 13.5" (glass width chart available upon request) Special sizes available.

Slings for Stone

- 16,300 lb. vertical load capacity per sling.
 - 3" wide x 102" long for lifting stone up to 80" high when using our SB-96 Spreader Beam.
 - Two ply slings with full length pads sewn on the inside of body for wear protection.
- * **SAFETY WARNING:** Check slings for wear and damage before each use.

Quantity	Part No.	Description	Weight-lbs.
1 Pair	SL-102	3" x 102" Endless loop	30

Distributed by Specialtytools.com
1 800 669 5519

GLASS & STONE STORAGE SYSTEMS

Spreader Beams for Glass

Part No.	Description	Weight-lbs.
SB-108	4" wide x 8" high x 108" long - 4,000 lb capacity. For use with slings up to 4" wide, handles glass up to 144" long.	145
SB-168	4" wide x 8" high x 168" long - 10,000 lb capacity. For glass case sizes up to 130" x 204".	600

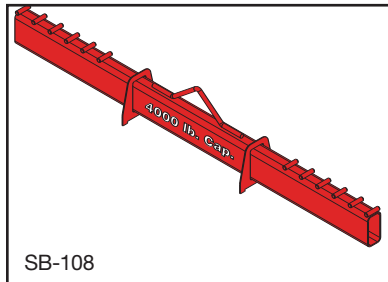

SB-108

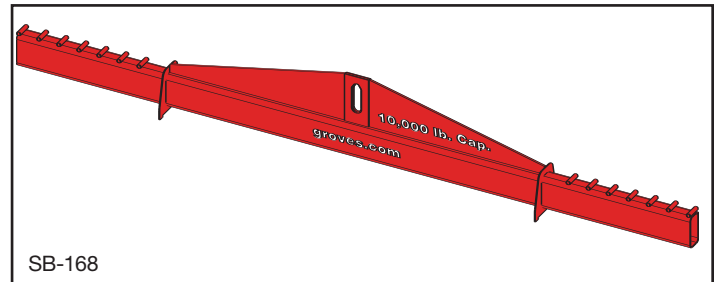
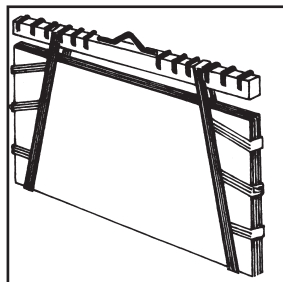

SB-168

Spreader Beams for Stone

- For use with slings up to 4" wide.
- Lifts with overhead crane or forklift.
- Removable pins on top of the beams hold slings in place for safety.

Part No.	Description	Weight-lbs.
SSB-96	5" wide x 5" high x 96" long - 10,000 lb capacity.	198

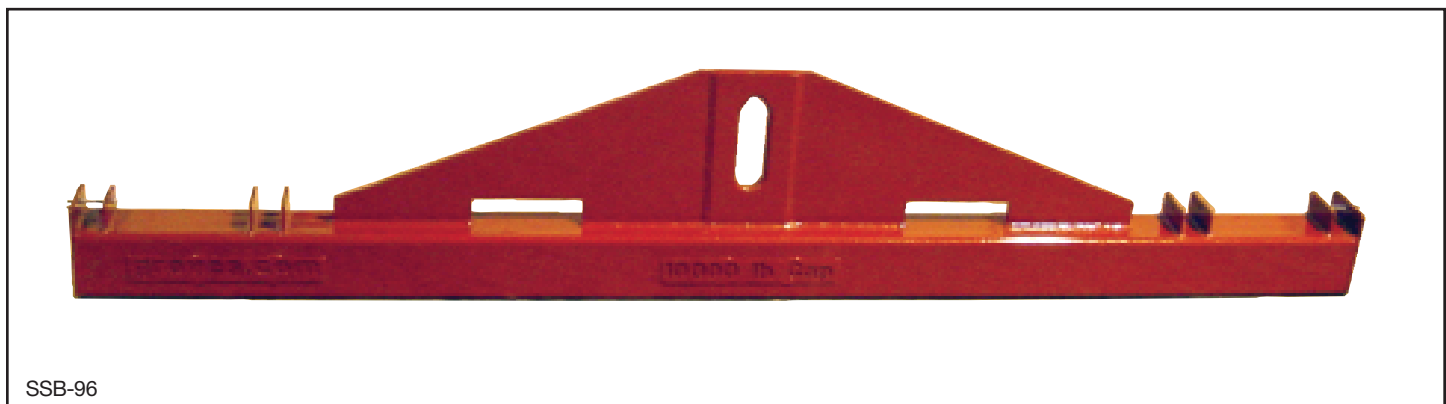

SSB-96

Distributed by Specialtytools.com
1 800 669 5519

GROVES KNOWS STORAGE

THE LARGEST SELECTION OF HEAVY DUTY STORAGE RACKS FOR GLASS & STONE



GROVES KNOWS TRANSPORTATION

BUILT-TO-LAST CARTS AND RACKS SPECIFICALLY DESIGNED FOR DEMANDING APPLICATIONS



GROVES KNOWS FABRICATION

INNOVATIVE TABLES AND STANDS DESIGNED BY TRADESMEN FOR THE INDUSTRY

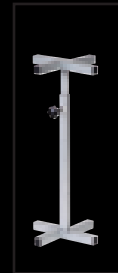

GROVES KNOWS HOW YOU MAKE A LIVING!

GROVES INCORPORATED

Distributed by Specialtytools.com

1 800 669 5519

www.specialtytools.com